

Transure

For The Road Ahead...

Issue 7

July 6, 2001

Try our online quoting options on our website @ TransureServices.com!

INSIDE THIS ISSUE:

| | |
|-----------------------------|-----|
| <i>Trucks Hard to Place</i> | 2 |
| <i>Safer...Safestat...</i> | 2-3 |
| <i>Captives</i> | 3-4 |
| <i>FMCSA Websites</i> | 4 |
| <i>Transure Information</i> | 4 |

“Long haul trucking scored a 4.2, falling between difficult market and impossible to place.”

For questions or suggestions, please feel free to contact Andy Sharpe at 800-326-8198 ext. 216 or andy@transureservices.com.

For the Road Ahead...

Trucks Hard-To-Place: N.Y. Agent Survey

Seeking to shore up its arguments that help is needed to adequately place some insurance lines, a New York state independent agent's association released a survey indicating how difficult it is for agencies to place some lines of insurance.

Professional Insurance Agents of New York released a survey asking member agencies about their experience in placing 10 different lines of property-casualty business. The agencies were asked to rate placing the business on a scale of one to five, from highly competitive to impossible to place.

Of the ten lines covered by the survey, PIANY noted that long-haul trucking, coastal property and general contractors scored the most difficult to place.

Long haul trucking scored a 4.2, falling between difficult market and impossible to place.

Coastal property scored a 3.9, just below difficult market, followed closely by gen-



At spaghetti intersection, one better not have too many meatballs.

eral contractors with a 3.7 average.

The need for the survey supports anecdotal evidence from member agents that some lines were becoming increasingly difficult to place within the state, said Ellen Kiehl, assistant executive director of government affairs for the Glenmont, N.Y.-based

association. The results, she said, support the association's efforts to reform laws in the state directly affecting the placement of some coverage and, in the case of long-haul trucking, indicated the need for help from other associations.

The results, said Ms. Kiehl, did not surprise association

SAFER...SAFESTAT...SEA...LICENSING

What do these words mean to you? SAFER, SAFESTAT and LICENSING are data bases maintained by the Federal Motor Carrier Safety Administration (FMCSA) and the Federal

Highway Administration (FHWA) and are available to anyone through the internet. Information on all motor carriers with a DOT number are contained in these data bases. We are letting you

know that the information contained in these websites are being used extensively by the insurance industry to see how you are doing, and how you compare to your peers. (cont. pg 2)

TRUCKS HARD-TO-PLACE: N.Y. AGENT SURVEY (CONTINUED)

"...agencies were asked to rate placing the business on a scale of one to five, from highly competitive to impossible to place."

"Underwriters pay close attention to how you score in the Overview and the History area."

executives, but only confirmed "what we were aware of and heard on the street." The survey, she said, gives an objective rating to the lines and will serve as a basis for future measurements.

The survey was either faxed or e mailed to agencies throughout the state. Although Ms. Kiehl did not know how many agencies received the survey, 185 of them responded, she said, noting that the association was pleased with the number of responses.

The results were broken down into five regions: Long Island, New York City's five boroughs, mid-Hudson, Westchester counties, and the rest of the state.

Regional variations came into play when puffing the figures together, with some regions not involved in the placement of some insurance.

Of the five regions surveyed, agencies only in New York City and Long Island responded that they placed coastal property lines.

In general contractors' lines, while agencies in all five regions reported writing these lines, those located in mid-Hudson and Long Island said the market was difficult. The other three regions fell be-

problems, an overall objective of the survey was to "help our members get markets opened to them," Ms. Kiehl said.

A copy of the survey was sent to the Professional Insurance Wholesalers Association

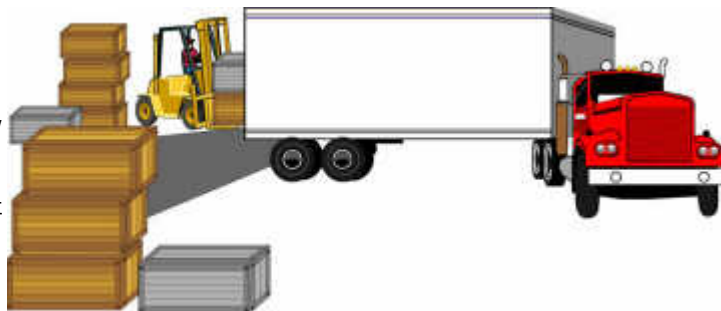

tween adequate market and difficult market in their scoring.

Few agencies reported writing long-haul trucking, with most of the coverage written by upstate agencies. The majority of agencies said the market for the coverage was either difficult or impossible to place.

This is the first survey PI-ANY has done since the mid-1980's, said Ms. Kiehl. In addition to quantifying the

of New York State, Inc. to see if markets can be opened up through alternative insurance markets.

The survey support's the association's legislative agenda to reform sections of the New York state labor law affecting contractors and retention of special legislative protections for property owners living in coastal areas.

Article by Mark E. Ruquet
- National Underwriter

SAFER...SAFESTAT...SEA...LICENSING (CONTINUED)

Our advice to you is to review these sites and make absolutely sure the information on you is accurate. If you have never visited these sites, you are in for a shock. How do I access these sites? SAFER which stands for the Safety And Fitness Electronic Records System, is accessed from the internet by going to

<http://www.safersys.org>. SAFER provides a snapshot look at your company in four categories: (1) ID/Operations, (2) Inspections and accidents for the past 24 months, (3) Safety Rating and (4) Insurance records. From the SAFER site, in the upper right hand corner you can link to the Licensing and Insurance information by clicking on that heading. If you

wish you can also get to this information at <http://fhwa-li.volpe.dot.gov>.

SafeStat provides a historical view of your safety performance over the past 30 months. This information is updated every six months. Underwriters pay close attention to how you score in the Overview and the History area. This site has specific categories of Acci-

Try our online quoting options on our website @ TransureServices.com!

SAFER...SAFESTAT...SEA...LICENSING (CONTINUED)

dents, Drivers, Vehicles and Safety. The information contained here is based on statistics that come from several places. More specifically, roadside state and federal inspections, MVRS, reported accidents, DOT inspections done at your place of business, and more. SafeStat can be accessed from the internet at

<http://www.ai.volpe.dot.gov/mcspa.asp>.

From the information in this site your SEA value is determined. This is a complicated system of comparisons that rate you as compared to the average, using your information.

Because this information is being used to evaluate you, it is imperative

you update what information you can, at least annually. This is done by filing a new MCS150. You can do that electronically by accessing your internet provider and going to <http://www.mchs.fhwa.dot.gov/factsfigs/dotno.htm>.

An example of the importance of updating information is...ABC motor carrier received his authority when he had but one truck operated by one driver. He has never updated the MCS150 and now operates a

fleet of 20 units and 25 drivers. After a few years, based on the stops at DOT checkpoints, MVRS and the FMSCA's belief that there is only one truck operating, the motor carriers SafeStat numbers are in the 90's. The FMSCA now deems this motor carrier unsafe when in reality had the motor carrier refiled the MCS150 showing the increase in trucks and drivers



he would most likely generate satisfactory statistics.

Unfortunately this is a two way street and reducing the number of units and drivers may have an adverse affect, and increase the SafeStat numbers.

Once you have seen what information is contained in these sites you will understand the impact on an insurance underwriter. He may allow credits or pass on your account due to the findings in these sites.

In order to help you access some important government websites for truckers we are listing them here on the back cover for future use.

**National
1999 Large Truck Crash
Facts**
<http://ai.volpe.dot.gov/>

- ▶ 4898 Large Trucks Involved in Fatal Crashes
- ▶ 5362 Fatalities in Crashes Involving Large Trucks
- ▶ 92760 Large Trucks Involved in Non-Fatal Crashes
- ▶ 49483 Large Trucks Involved in Injury Crashes
- ▶ 74609 Injuries in Crashes Involving Large Trucks
- ▶ 85106 Large Trucks Involved in Tow away Crashes
- ▶ 8857 Large Trucks Involved in Hazmat (HM) Placard Crashes

Data Source:

- ▶ Fatality Analysis Reporting System (FARS).
- ▶ Motor Carrier Management Information System (MCMIS) Crash File.

"...this information is being used to evaluate you, it is imperative you update what information you can, at least annually."

HEARD ABOUT A CAPTIVE LATELY?

With the insurance marketplace a sham-bles, you may here a lot of talk from some brokers about the alternative market. The alternative market is a fancy name for a plan to sell you on a captive or a risk retention group. These type programs become popular when the insurance marketplace tightens.

Transure has looked into some of these programs and although we have seen some very good ones, we have yet to find one that offers you an advantage over traditional placements. It seems all these plans have some advantages but also pitfalls. Things to think about when considering a captive:

Who owns it?. Is it member owned or a rent-a-captive? Does an Insurance broker own it? Who manages it and who handles the claims?

After all the expenses, taxes and reinsurance costs, what is left to pay claims?

What is my deductible if any, and are other members able to have different deductible levels? Why?

Are losses aggregated? Is there a maximum I can pay?

Is there a possibility of an assessment if losses are poor. This may be shown as joint and several liability in the prospectus. Who is assessed and for what and when?

(Continued on back page)

Try our online quoting options on our website @ TransureServices.com!



HEARD ABOUT A CAPTIVE LATELY? (CONTINUED)

Is the captive homogeneous (all Truckers), or heterogeneous (other industries admitted)?

Do I have to invest in the plan? Also known as surplus contribution. Is the investment vehicle shares of stock? Is the stock in the name of the Captive/Risk Retention Group, or some other entity such as a trucking association?

How does the reinsurance work? Where does it attach and who is the carrier/underwriter?

Are there numerous disclaimers in the proposal? Why?

Once I am in, how do I get out? What will it cost me?

An excellent resource for information on these types of insurance programs is The Risk Retention Reporter. They can be accessed on the internet at <http://www.rrr.com>. They follow and report on more than 850 alternative market companies.

Remember, if it sounds too good to be true, it may not be true. Keep in mind insurance regulations always apply to the seller, who is prevented from selling insurance without a license. They do not apply to the buyer, who in most cases is free to buy from anyone he chooses. In this market, be selective with whom you do business and do your homework on the product he or she is bringing to you.

We're on the web!
Transureservices.com

For The Road Ahead...



**3060 S Church St
Burlington, NC 27216
Phone: 336-584-9494
Fax: 336-584-9414**

CHECK OUT OUR WEBSITE AT:

WWW.TRANSURESERVICES.COM

THE LINKS BELOW ARE AVAILABLE ON OUR WEBSITE.

FMCSA WEBSITES OF IMPORTANCE

- What is the Federal Motor Carrier Safety Administration official website address?
www.fmcsa.dot.gov
- How can I locate the nearest field office?
www.fmcsa.dot.gov/aboutus/aboutus.htm
- What must I do to start a trucking business?
www.fmcsa.dot.gov/factsfigs/formspubs.htm
- Where can I obtain information about Federal safety regulations and interpretations?
www.fmcsa.dot.gov/rulesregs/fmcsrhome.htm
- How do I obtain at DOT number?
www.fmcsa.dot.gov/factsfigs/formspubs.htm
- How can I obtain information about a motor carrier, broker, or freight forwarder's application, insurance, and process agent?
<http://fhwa-li.volpe.dot.gov>
- Where can I file forms and pay fees for registration, insurance, and fines?
<http://diy.dot.gov>
- How can I obtain a motor carrier's Profile?
www.safersys.org/snpquery.asp
- Where can I find detailed information about a motor carrier's safety performance?
<http://al.volpe.dot.gov>
- How can I change the name and address of my business online?
<http://diy.dot.gov>
- Where can I find carrier safety ratings, inspections, and accident summary data?
www.safersys.org/snpquery.asp
- How do I report safety violations?
www.fmcsa.dot.gov/pdfs/saftviolationrpt.pdf
- Where can I find the latest information about safety programs?
www.fmcsa.dot.gov/safetyprogs/saftprogs.htm
- Where can I find information about the transportation of Hazardous Materials?
<http://hazmat.dot.gov>
- How can I obtain the latest research and analysis on truck and bus safety?
www.fmcsa.dot.gov and <http://al.volpe.dot.gov>